

CRIO Line CP 2 Door Refrigerated Counter, 265lt (-2/+10) - No top (R290)

ITEM # _____

MODEL # _____

NAME # _____

SIS # _____

AIA # _____



721100 (AA2R5AA)

2-door refrigerated counter, -2/+10°C, full AISI 304 (R290), without work top, with right cooling unit

Short Form Specification

Item No. _____

AISI 304 stainless steel panels, AISI 304 bottom panel, AISI 304 back panel. N. 2 full doors. Built-in refrigeration unit. Operating temperature: -2/+10°C. R290 gas in refrigeration circuit. Supplied with 1 grid for each door compartment

Main Features

- Adjustable temperature range from -2 °C to +10 °C to suit meat, fish and dairy storage requirements.
- Combination of doors and drawers to suit varying needs, with the possibility to change the configuration on site.
- Digital control panel.
- Forced air circulation for rapid cooling and an even temperature distribution.
- Refrigerated compartment designed to accept GN 1/1 containers.
- Equipped with forced air circulation system for rapid cooling and temperature distribution within the cell.
- Combination of doors and drawers to suit any configuration need, with the possibility to change the configuration on site.
- Preservation performances and temperature uniformity within the cell guaranteed at 5-HEAVY DUTY (40°C) working conditions according to EN16825:2016 test protocol.
- Equipped with Airflow system: forced air circulation system for rapid cooling and even temperature distribution within the cell.
- 0mm clearance installation space: tower configuration cooling unit guarantee performance with frontal ventilation only; this unique solution allows installation against the wall or side by side with other appliances, even on the cooling unit side to maximize the use of kitchen space.
- Combination of doors and drawers to suit any configuration needed, with the possibility to change the configuration on site. Right cooling unit available on request.
- Frontal and easy access to all components in the cooling unit.
- Fully compliant HACCP digital control: when temperature exceeds critical limits, acoustic and visual alarms are activated. Up to two months of event are kept in memory.
- Anti-tilt runners accept GN 1/1 containers.
- Self closing stainless steel doors (< 90°).
- Certified safety CE requirements.
- Prearranged to fit RS485 port to facilitate connection to a remote computer and integrated HACCP systems.
- Hot gas automatic evaporation of defrost water.
- Connectivity ready for real time access to connected appliances from remote and data monitoring (requires optional accessory).
- Digital white-digit display with internal temperature display and setting, manual activation of defrost cycle and turbo frost cycle (to rapidly cool warm loads).
- Easy serviceability thanks to the intuitive control panel with access via app.
- Integrated RS485 port to facilitate connection to a remote computer and integrated HACCP systems.
- Tropicalized unit.

Construction

- Access to all components from the front.
- Built-in compressor to suit operating conditions.
- Developed and produced in ISO 9001 and ISO 14001 certified factory.
- Fault code display.
- Interior base with rounded corners, pressed from a single sheet.
- Internal and external doors, front, back and side panels in

APPROVAL: _____

- AISI 304 Stainless steel.
- Mounted on Stainless steel adjustable legs to give 150 mm clearance for ease of cleaning.
- Rounded internal corners for ease of cleaning.
- Constructed from AISI 304 Stainless steel throughout to meet the highest hygiene standards.
- Pre-arranged for drain-pipe.
- Built-in refrigeration unit.
- Anti-drip profile on stainless steel worktop edge.
- 2 compartments with 2 doors.
- Mounted on stainless steel feet to give 150 mm (-5/+50 mm) clearance for ease of cleaning the floor.
- External bottom panel in stainless steel.
- Ease of cleaning and high hygiene standards thanks to the rounded internal corners, the easily removable runners, grids and air conveyors.
- Internal structure with 15 charging positions (3 cm pitch) available to host GN 1/1 grids, ensuring higher net capacity and a greater storage space.
- Excellent space optimisation thanks to the compact dimensions.
- Extractable cooling unit to facilitate maintenance.
- IP21 protection index.

- 1/3 and 2/3 bottle drawer kit for refrigerated counters PNC 881187
- Kit 4 wheels, h100mm (2 with brakes) for refrigerated counters PNC 881191
- Kit 4 wheels, h150mm (2 with brakes) for 2&3 compartment refrigerated counters PNC 881193
- Lock for refrigerator/freezer counters with 2 compartments - h650mm PNC 881245

Sustainability

- IQ Defrost - fully automatic defrost starts only when ice is actually building-up in the evaporator and adapts the defrosting duration to guarantee perfect ice removal while optimizing energy efficiency consumption.
- Fitted with 90 mm thickness of cyclopentane insulation for best insulating performance (thermal conductivity: 0,020 W/m*K) and lowest environmental impact (GWP=3).
- Removable triple-chamber balloon magnetic gasket to improve insulation and reduce energy consumption and ease of cleaning.
- Extra insulation: 90mm body insulation to minimize energy dispersion.
- CFC and HCFC free, highly ecological refrigerant type: R290 (ecological gas in foam: cyclopentane). Hydrocarbon refrigerant gas R290 for the lowest environmental impact (GWP=3), to reduce green house and ozone depletion effects.

Included Accessories

- 2 of Kit 1/1GN gray rilsan grid and 2 side runners for refrigerated counters PNC 881109

Optional Accessories

- 1/1GN gray rilsan grid for refrigerated counters PNC 881107
- 2 side runners for 1/1GN refrigerated counters PNC 881108
- Kit 1/1GN gray rilsan grid and 2 side runners for refrigerated counters PNC 881109
- 1/1GN plastic container, h65mm PNC 881110
- 1/1GN plastic container, h100mm PNC 881111
- 1/1GN plastic container, h150mm PNC 881112
- Worktop for refrigerated Crio Line CP and SB counters - 2 compartments PNC 881124
- Worktop and upstand for refrigerated Crio Line CP and SB counters - 2 compartments PNC 881127
- 2-drawer kit refrigerated counters PNC 881179
- 3x1/3-drawer kit for refrigerated counters PNC 881186



CRIO Line CP
2 Door Refrigerated Counter, 265lt (-2/+10) - No top (R290)

The company reserves the right to make modifications to the products without prior notice. All information correct at time of printing.

Side

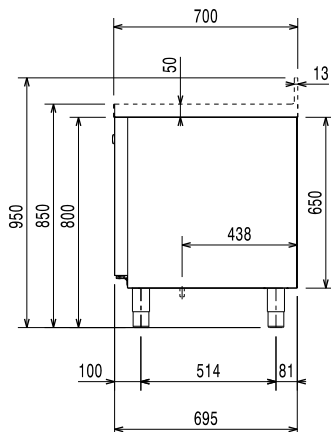

Front

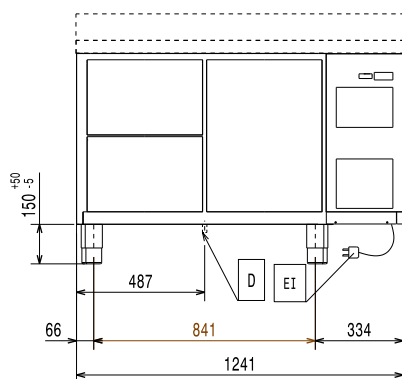

EI = Electrical inlet (power)

Top

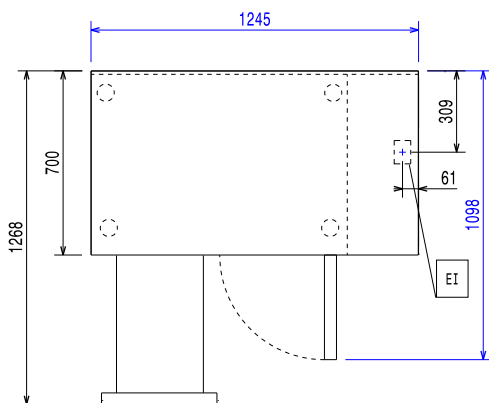

Electric

Supply voltage: 220-240 V/1 ph/50 Hz
Electrical power max: 0.22 kW

Key Information:

Remote Compressor and Refrigeration Unit

Net Volume: 163.6 lt
N° of doors: 2
Door hinges: 2
External dimensions, Width: 1241 mm
External dimensions, Depth: 700 mm
External dimensions, Depth with Doors Open: 1110 mm
External dimensions, Height: 800 mm
Depth with doors open: 1110 mm
Gross capacity: 265 lt

Refrigeration Data

Control type: Digital
Refrigeration power at evaporation temperature: -10 °C
Operating temperature min.: -2 °C
Operating temperature max.: 10 °C
Compressor power: 0.25 hp
Operating mode: Ventilated
Defrost type: Manual
N° defrost in 24 hrs: 1

Sustainability

Refrigerant type: R290
GWP Index: 3
Refrigeration power: 358 W
Energy Class (EU Reg. 2015/1094): A
Yearly and daily energy consumption (EU Reg. 2015/1094): 400kWh/year - 1kWh/24h
Climate class (EU Reg. 2015/1094): Heavy Duty (5)
Energy Efficiency Index-EEI (EU Reg. 2015/1094): 18,12

ALPENINOX

CRIO Line CP 2 Door Refrigerated Counter, 265lt (-2/+10) - No top (R290)



EU energy labelling from 1st July 2016

The European energy labelling scheme for professional refrigerators and freezers is based on requirements setting Minimum Energy Performance standards for commercial refrigeration cabinets sold within the EU. These requirements are designed to drive energy efficiency and environmentally friendly approach for professionals. The European energy labelling scheme will apply to all manufacturers and importers who sell and market products within the EU and it is mandatory across Europe. Important: all products which consume energy above the minimum level will not be able to be sold within the EU from 1 July 2016.

SI 2020 No. 1528.

Important: all products which consume energy above the minimum level will not be able to be sold within the EU from 1 July 2016.



**CRIO Line CP
2 Door Refrigerated Counter, 265lt (-2/+10) - No top (R290)**

The company reserves the right to make modifications to the products without prior notice. All information correct at time of printing.

2025.04.25

EU energy labelling from 1st July 2016

The European energy labelling scheme for professional refrigerators and freezers is based on requirements setting Minimum Energy Performance standards for commercial refrigeration cabinets sold within the EU. These requirements are designed to drive energy efficiency and environmentally friendly approach for professionals. The European energy labelling scheme will apply to all manufacturers and importers who sell and market products within the EU and it is mandatory across Europe. Important: all products which consume energy above the minimum level will not be able to be sold within the EU from 1 July 2016.

SI 2020 No. 1528.

Important: all products which consume energy above the minimum level will not be able to be sold within the EU from 1 July 2016.

